

# Ergo-Boost Foot Rocker



# Ergo-Boost

## Foot Rocker

### Stay active while you work

When you are sitting in front of a screen all day, it can be challenging to remain active. The Ergo-Boost Foot Rocker allows for low impact movement by rocking your feet, providing additional lower leg mobility while sitting. When not in use as a rocker, it can be utilised as an elevated ergonomic footrest, for added comfort.



### Why choose Ergo-Boost Foot Rocker?

#### Choice of exercise settings

The 2-in-1 design means that you can choose between a slow rocking motion (high setting) and a quick rocking motion (low setting) for different exercise rhythms.

#### Added comfort

Choose between two different height positions for added comfort when using as a footrest.

#### Anti-slip design

For added stability.

#### Reduces fatigue

When not in use as a rocker, the Ergo-Boost Foot Rocker can be utilised as an elevated ergonomic footrest.

#### Compact

The foot rocker is unobtrusive and compact enough to store away under the desk when not in use.

#### Peace of mind

5 years warranty, for peace of mind.



# Ergo-Boost

## Foot Rocker

- 1 Setting for slow rocking motion (high setting)
- 2 Setting for quick rocking motion (low setting)
- 3 Anti-slip design for stability
- 4 Massage bumps rejuvenate tired feet
- 5 Compact size for easy storage
- 6 Choice of height position



# Ergo-Boost

## Foot Rocker

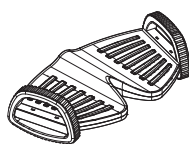
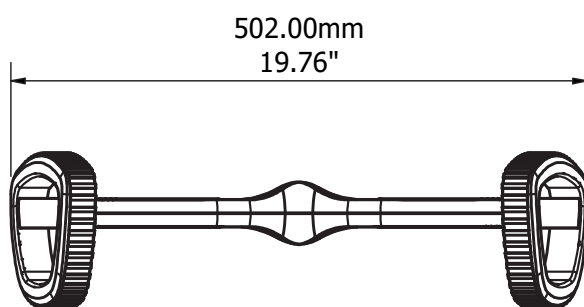
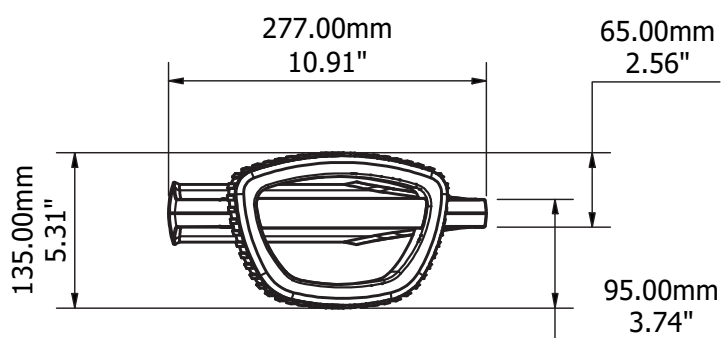
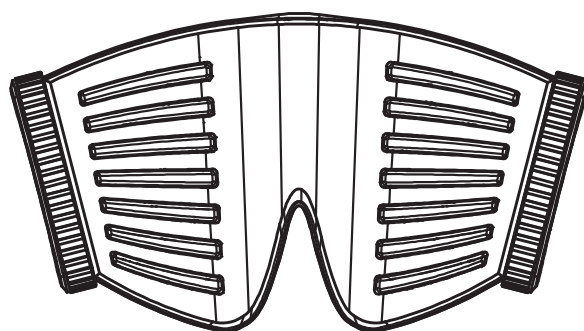

Ergo-Boost Foot Rocker	Weight capacity	Tilt range	Material	Colour
FR001	10kg	+45° / -45° (high setting) +10°/-10° (low setting)	Plastic	Black



Create workspaces that work.

Contact Adapt Deutschland GmbH for more information,  
pricing and samples.

+49 (0) 2154 891 40 0

[infode@adapt-global.com](mailto:infode@adapt-global.com)

[www.adapt-deutschland.eu](http://www.adapt-deutschland.eu)