

# Ergo-Boost Monitor Arm



# Ergo-Boost Monitor Arm

## Smooth, precise, flexible

The Ergo-Boost Monitor Arm lets users work in comfort all day long. Its gas spring system allows monitors to be moved with precision and the extended reach offers exceptional ranges of height and width adjustment. This means the arms can accommodate different working postures, as well as a wide range of monitor sizes. They are available in single and double configurations.



## Why choose the Ergo-Boost Monitor Arm?

### Smooth, accurate movement

The arms can be adjusted with ease, allowing users to work in comfort all day long.

### Integrated cable management

Integrated cable management along the arm and the base mean wires are kept neat and tidy.

### Flexible

The flexible arms offer a wide range of vertical and horizontal adjustment, suiting them to even the widest of monitors. They can accommodate monitors between 17-32".

### Future-proof

Each arm can hold monitors weighing between 1 – 9kgs, which means that they can adapt to new monitors in the future.

### Fixes to most worksurfaces

C-clamp and Bolt Through mounting are both included as standard. The mounts can be adjusted to worksurfaces of 10mm – 80mm thick.

### Peace of mind

5 years warranty, for peace of mind.



# Ergo-Boost

## Monitor Arm

- 1 Integrated cable management on arms and base
- 2 Gas spring counterbalance
- 3 180° rotation stop prevents excess movement
- 4 Integrated USB sockets
- 5 Quick connect VESA mount with lock
- 6 Counterbalance adjustment
- 7 Low profile double hub base
- 8 Silicone padding prevents movement, while protecting the desktop from scratches
- 9 C-clamp and Bolt Through mounting options

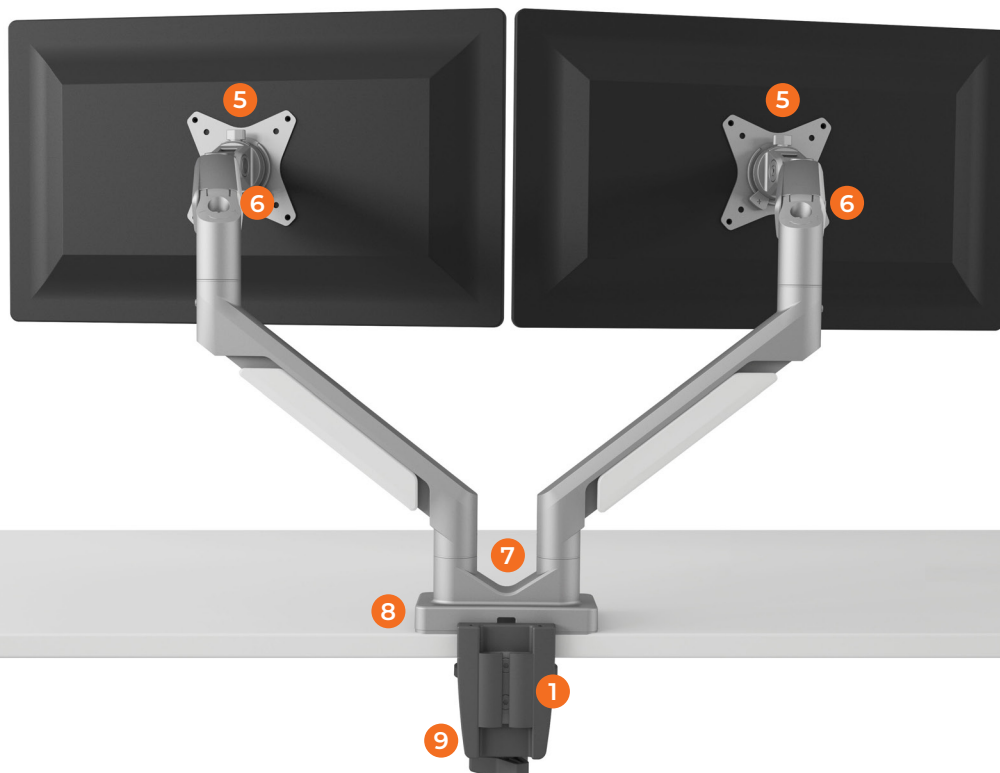
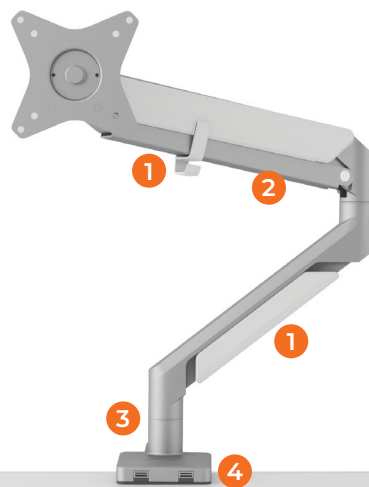

# Ergo-Boost

## Monitor Arm

### Single Monitor

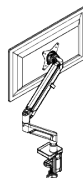
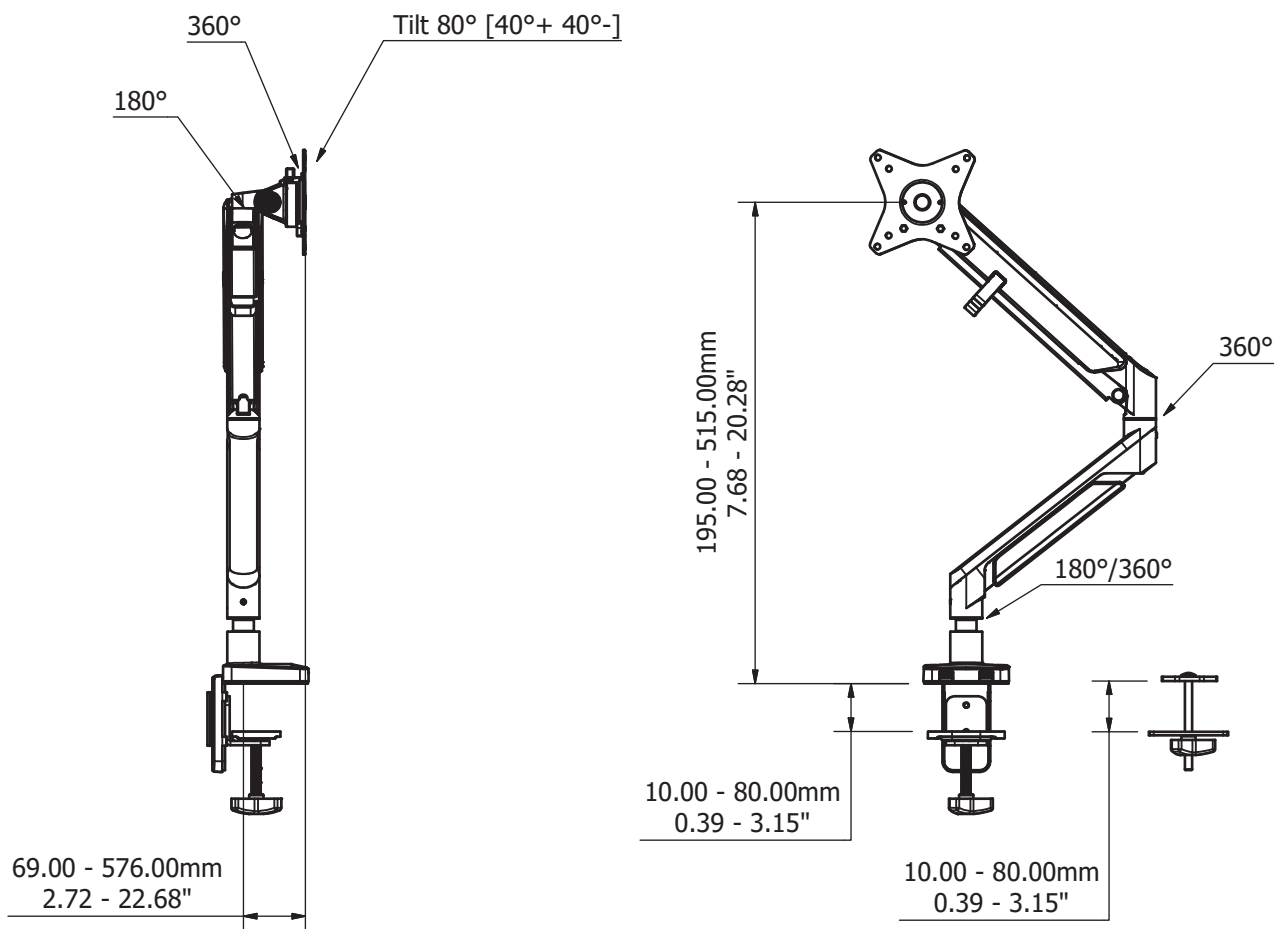

Monitor arm	Weight range	Maximum vertical reach	Maximum horizontal reach	Rotation	Tilt
GA01-BTCC	1 – 9kg	515mm	576mm	180° +/- 180° -	40° +/- 40° -

Colours available:		Construction	
Black/Space Grey (BK)	White/Silver (WT)	Aluminium, plastic and steel	

# Ergo-Boost

## Monitor Arm

### Single Monitor

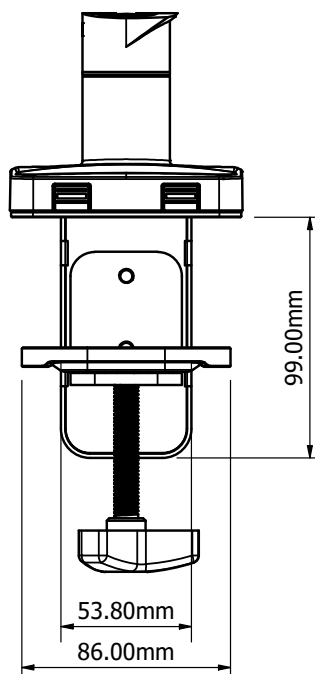
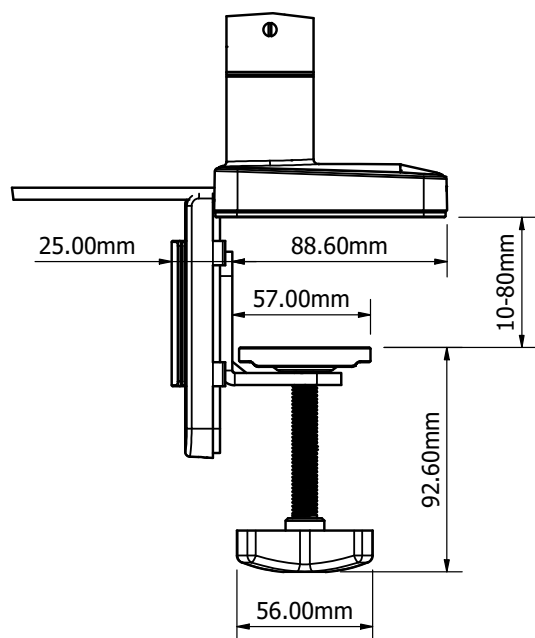
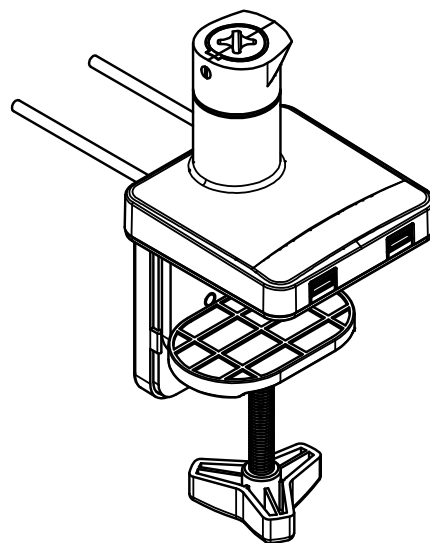
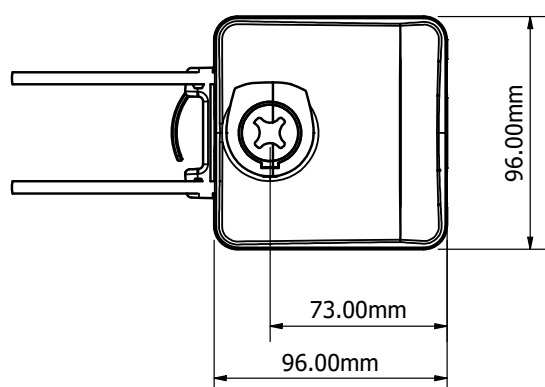

# Ergo-Boost

## Monitor Arm

### Double Monitor

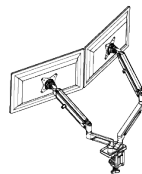
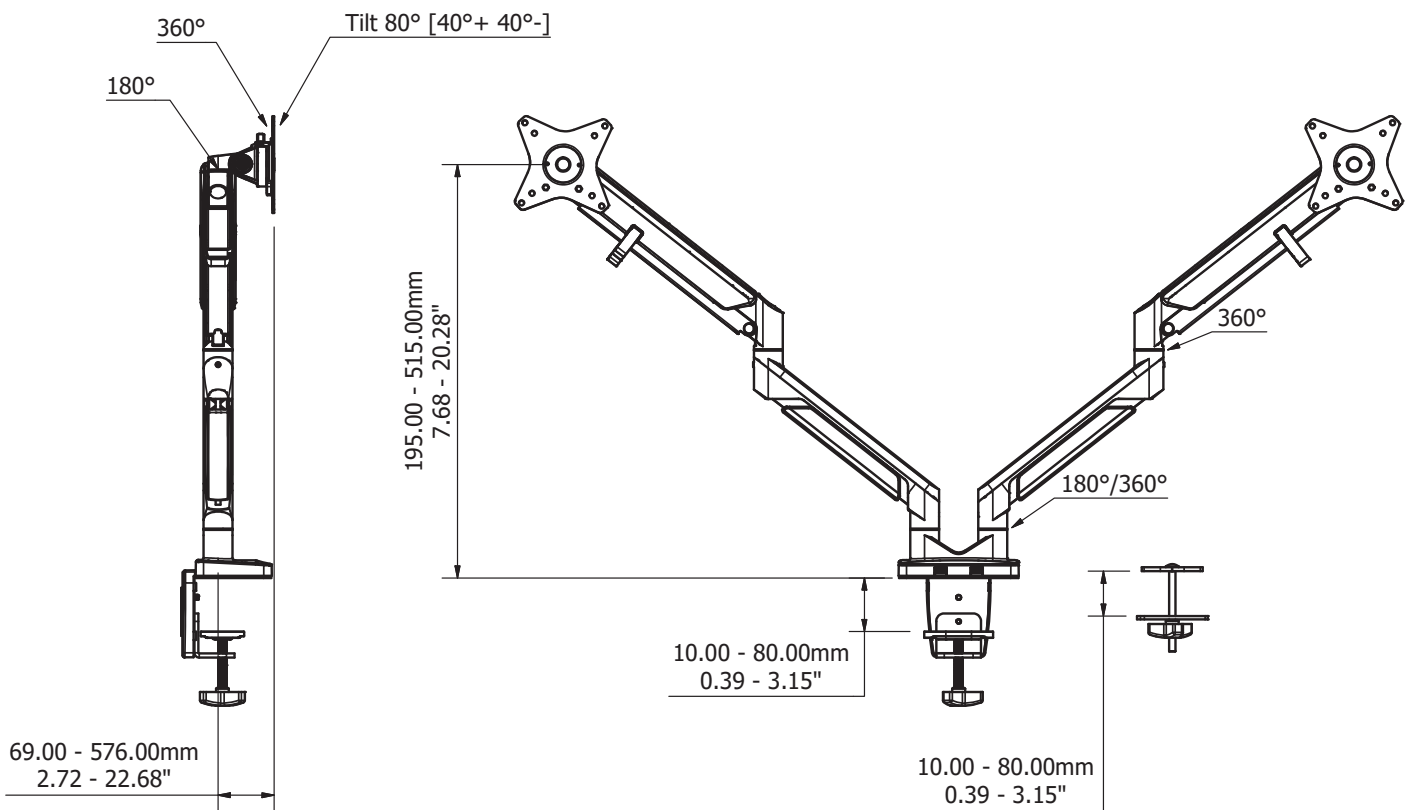

Monitor arm	Weight range	Maximum vertical reach	Maximum horizontal reach	Rotation	Tilt
GA02-BTCC	1 - 9kg	515mm	576mm	180° +/- 180° -	40° +/- 40° -
Colours available:			Construction		
Black/Space Grey (BK)		White/Silver (WT)	Aluminium, plastic and steel		





# Ergo-Boost

## Monitor Arm

### Double Monitor

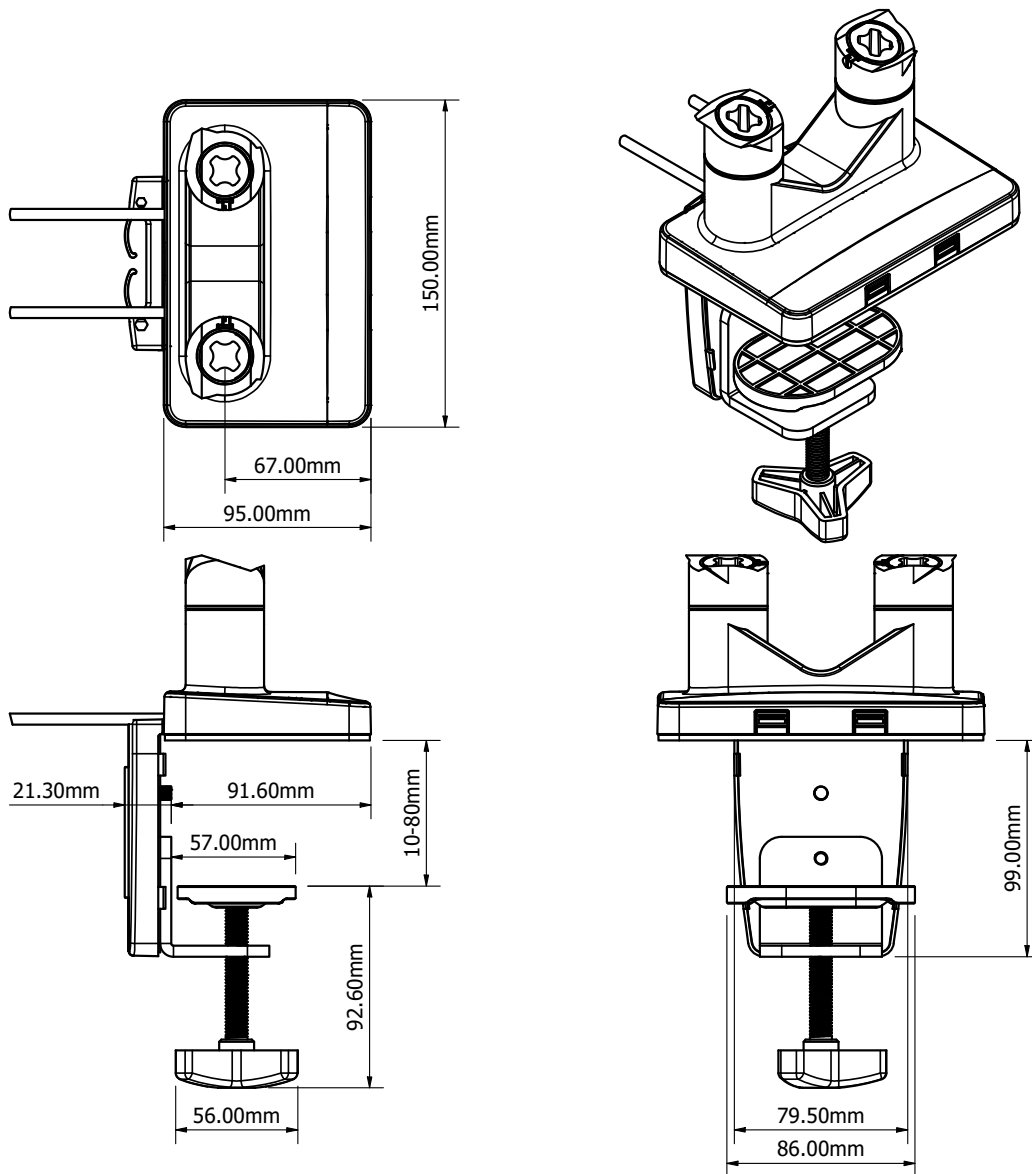



Create workspaces that work.

Contact Adapt Deutschland GmbH for more information,  
pricing and samples.

+49 (0) 2151 985 190

[infode@adapt-global.com](mailto:infode@adapt-global.com)

[www.adapt-deutschland.eu](http://www.adapt-deutschland.eu)