

# Ergonomics needs Lighting

LED task lighting from Adapt



Many physical and psychological factors play a part in creating a safe, comfortable and productive working environment. Not least among these is lighting.

Whilst positioning workstations to prevent glare from natural light sources either behind or in front of the user is critical, and providing adequate overhead lighting for an entire room is important, the benefits of individually adjustable task lighting for all workstation users are often forgotten.

A high-quality LED task light will provide the correct amount of light in precisely the required position, whatever the user is doing. Many studies have shown that good lighting, configurable at the user level, reduces eye strain, eliminates fatigue, improves focus, and, therefore, improves comfort and productivity.

At Adapt Deutschland, our focus is on fitting the working environment to the people using it, and that is why we are proud to introduce our new range of LED task lighting solutions focused solely on improving comfort and well-being.

Seamlessly integrating modern lighting technology and flexible monitor mounts for perfect workplace ergonomics.



Future-proof designs



Customised solutions



Customer support



Product continuity



5 Years Warranty



Sustainable solutions

## **The importance of individually adjustable task lighting in an office environment.**

Individually adjustable task lighting is an essential element of a well-designed office environment, offering significant benefits for productivity, health, and overall well-being. Unlike fixed overhead lighting, task lighting allows each employee to tailor illumination to their specific needs, creating a more comfortable and efficient workspace.

### **How it positively impacts productivity, health, and well-being, and how it should be adjusted to assist users across varying age groups.**

One of the most immediate advantages of adjustable task lighting is its impact on productivity. When lighting is properly aligned with the task being performed, employees can see more clearly and work with greater precision. Poor lighting—whether too dim or excessively bright—can lead to eye strain, reduced concentration, and increased errors. By giving individuals control over brightness and direction, task lighting helps maintain focus and reduces fatigue, enabling employees to sustain higher levels of performance throughout the day.

Health and well-being are also closely tied to lighting conditions. Inadequate lighting can contribute to headaches, eye discomfort, and even poor posture as workers lean or strain to see their work more clearly. Individually adjustable lighting reduces these risks by ensuring that light is directed exactly where it is needed, minimising glare and shadows. In addition, the ability to adjust colour temperature can support circadian rhythms: cooler light can enhance alertness during working hours, while warmer tones can create a more relaxed atmosphere when appropriate. This flexibility promotes both physical comfort and mental well-being, contributing to a healthier workplace overall.

The importance of adjustable lighting becomes even more apparent when considering the needs of users across different age groups. As people age, their visual acuity decreases, and they typically require higher light levels to perform the same tasks comfortably. Older workers may also be more sensitive to glare, making proper positioning and diffusion of light critical. Younger employees, while generally requiring less illumination, still benefit from the ability to adjust lighting to reduce long-term strain, especially when working extensively with screens. A well-designed task lighting system should therefore offer a wide range of brightness levels, smooth dimming capabilities, and flexible positioning to accommodate these varying needs.

### **How the initial investment in task lighting can ultimately save on lost working hours, reduced productivity, and energy costs.**

Although the initial investment in high-quality task lighting may seem significant, it often results in long-term cost savings. Improved lighting reduces the likelihood of errors and rework, saving time and minimising wasted effort. It also helps prevent health-related issues that can lead to absenteeism or decreased productivity. Furthermore, modern task lighting solutions—particularly LED-based systems—are highly energy efficient. By allowing employees to rely less on general overhead lighting and instead use targeted illumination, organisations can reduce overall energy consumption and lower utility costs. Over time, these savings can offset the upfront cost while also advancing sustainability goals.

### **What features should you look for when selecting the right task lighting for your office?**

When selecting task lighting for an office, several key features should be considered. Adjustability is paramount; look for lights with articulated arms, adjustable heads, and intuitive controls. Dimming functionality and variable colour temperature settings provide additional flexibility. Glare-reduction features, such as diffusers or anti-glare designs, are essential for visual comfort, especially in screen-based work environments. Energy efficiency, typically achieved through LED technology, should also be a priority, along with long lifespan and low maintenance requirements. Finally, ease of use and ergonomic design ensure that employees will actually take advantage of the lighting's capabilities.

**In conclusion, individually adjustable task lighting is a valuable investment that enhances productivity, supports health, and accommodates diverse user needs. By improving visual comfort and reducing energy use, it delivers both human and financial benefits, making it a critical component of any modern office.**



# Tolomeo meets SpaceArm

## Two timeless products together for perfect illumination of office workstations

Most modern workstations are equipped with at least two monitors or a large curved screen. This leaves little space for ergonomically optimised illumination of the work surface, exactly where the user needs it.

The combination of SpaceArm from Adapt and Tolomeo Mini from Artemide makes this possible due to a unique connection solution that seamlessly integrates the two products.



Future-proof  
designs



Customised  
solutions



Customer  
support



Product  
continuity



2 Year  
Warranty



Sustainable  
solutions

SpaceArm monitor mounts and the Tolomeo from Artemide share many similarities: both consist of a characteristic articulated arm system that allows for easy height and inclination adjustment thanks to integrated technology.



The Tolomeo mount is integrated directly into the SpaceArm hub, allowing light to be emitted over the monitors onto the work surface. The user can therefore adjust the position of their monitors and the light flexibly, individually, and without losing space.



Tolomeo Mini is controlled via a microswitch dimmer with an on/off function, located within easy reach of the employee.



# Key Features

- **Colour** - Polished aluminium
- **Installation** - Table
- **Material** - Aluminium, steel
- **Series** - Design Collection
- **Design by** - Michele De Lucchi, Giancarlo Piretti

## SpaceArm Mount

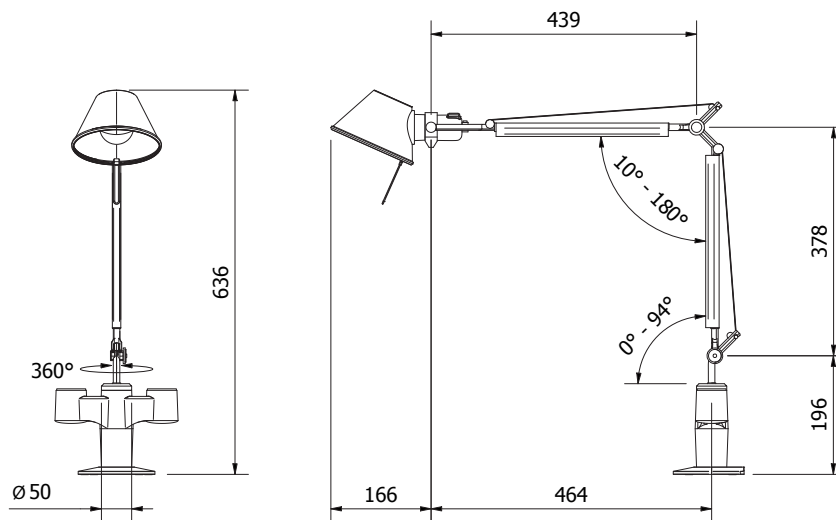

## Desk Base

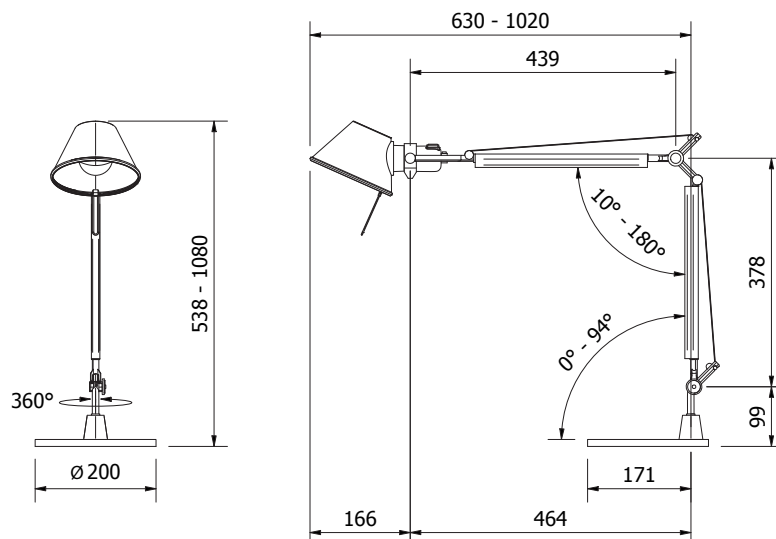

Product Code	Description
LIHT-ATMINI-DB -ALU SILVER	Tolomeo Mini LED table lamp with base
LIHT-ATMINI-507 -ALU SILVER	Tolomeo Mini LED table lamp with connection to SpaceArm mount
SPCA-507BK-AL-PT	Adapter for Tolomeo Lighting, Assembly to SpaceArm Double Hub - Black



# Beba LED Task Light

Modern Lighting Technology + Flexible Mounting Options = Better Workplaces



The clean, understated design of the BEBA LED Task Light integrates perfectly into any working environment. The material and surface finish not only give the luminaire a modern and sophisticated look but also a remarkable lightness and robustness.

The slim, 3-dimensionally adjustable head ensures uniform light distribution on the table surface without hot spots. Operation is via touch-sensitive buttons on the lamp head within direct reach of the employee.

Modern workstations often have at least two monitors or a large, curved screen. Sometimes this leaves very little space for ergonomically optimised illumination of the desk surface where the user needs it. So along with conventional mounting options, Adapt offers the unique combination of the SpaceArm monitor mount and the BEBA LED Task Light.



# Mounting Options

The BEBA LED Task Light is available with several mounting solutions to keep things flexible for the end user.



## SpaceArm Mount

BEBA LED Task Light can be integrated into the SpaceArm hub to emit light across the screen(s) and onto the work surface. This allows the user to adjust the position of the monitor arm and the lamp individually to suit their work needs without losing valuable desk space.

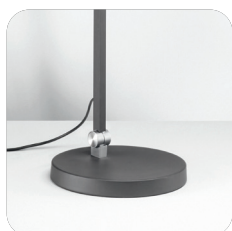

## Weighted Base

BEBA LED Task Light can be specified with a minimalist weight desk base so it can be positioned and moved anywhere on the working surface that extra lighting is required. This is especially useful when the user needs to perform writing or reading tasks away from their keyboarding area.



## C-Clamp

BEBA LED Task Light can be ordered with a C-clamp base to save working space and mount the light securely to the rear or ends of the desk surface.

Product Code	Description
LIHT-FL-B-509-WHT	White Beba table lamp with connection to SpaceArm
LIHT-FL-B-DB-WHT	White Beba table lamp with weighted desk base
LIHT-FL-B-CC-WHT	White Beba table lamp with C-Clamp
LIHT-FL-B-509-LBLK	Black Beba table lamp with connection to SpaceArm
LIHT-FL-B-DB-LBLK	Black Beba table lamp weighted desk base
LIHT-FL-B-CC-LBLK	Black Beba table lamp with C-Clamp



# Key Features



 **Power**  
ON/OFF

 **Brightness**  
Touch **LESS** than **0.5 seconds**  
**MAX** – 1340 Lumen  
**MID** – 50%  
**MIN** – 20%

Touch **LONGER** than **0.5 seconds**  
**MAX** – 1340 Lumen  
**MIN** – 20%

 **HUE**  
Touch-sensitive three-position  
colour temperature button

Cold White  
6000 K



Daylight  
4000 K

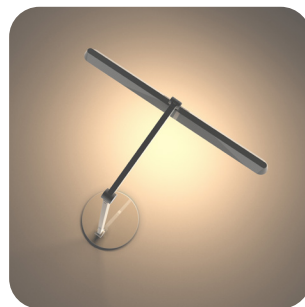

Warm White  
3000 K

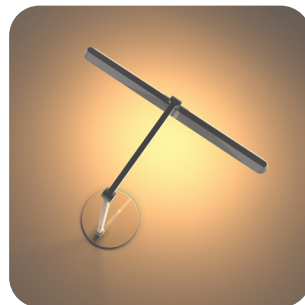
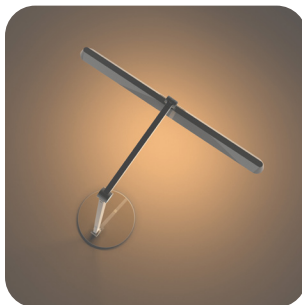
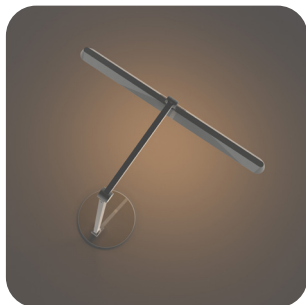

**MIN**

268 Lumen



**MID**

670 Lumen



**MAX**

1340 Lumen  
at least 500 Lux



# Technical Specifications

## Weighted Base

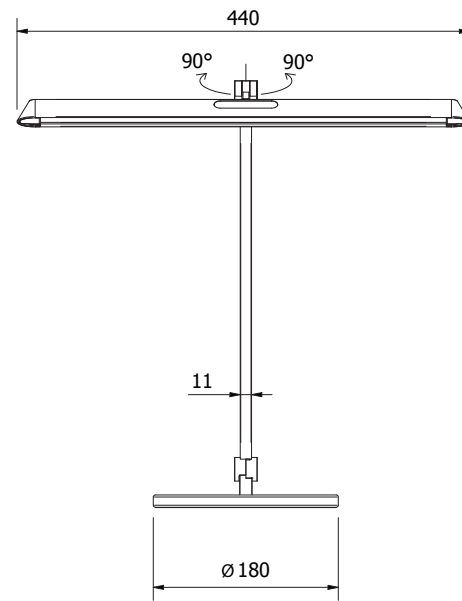
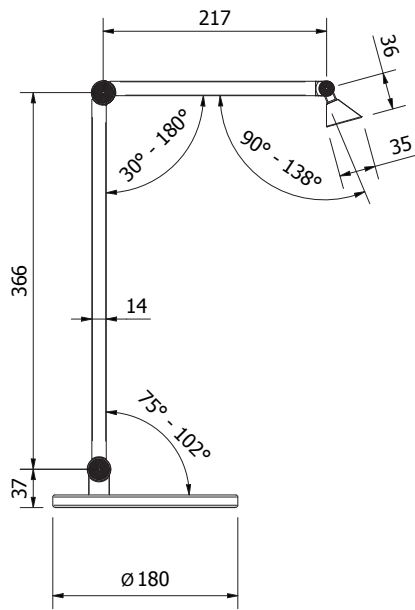

## Double Hub Mount

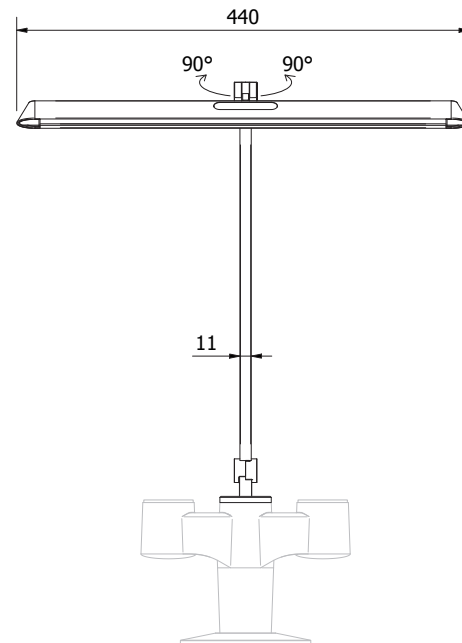
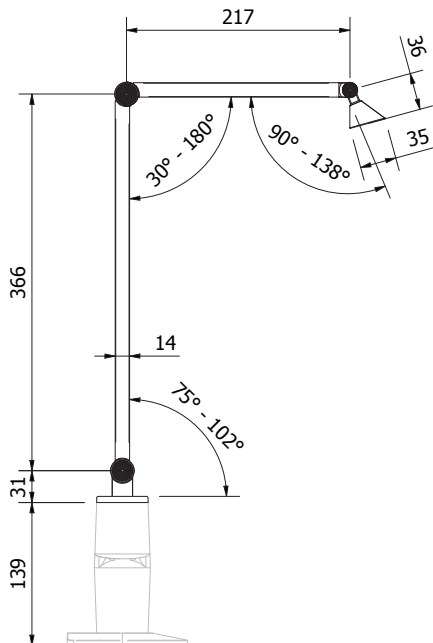

- **Construction** - Aluminium and Polymer
- **Colours** - White or Anthracite Black
- **Power cable** – 2 metres
- **Power supply** – 12W
- **Certified** - CE Certified
- **Energy usage** – Class E
- **Ingress-rated** - IP20
- **Double insulated** - Class II
- **Warranty** – 5 years\*

\*Subject to Terms and Conditions.



# Technical Specifications

## C-Clamp

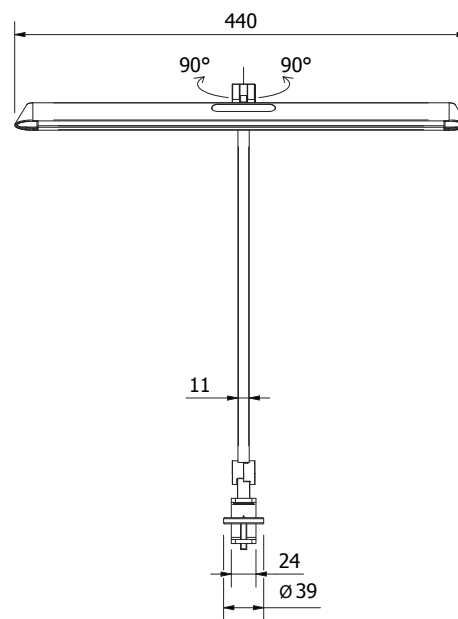
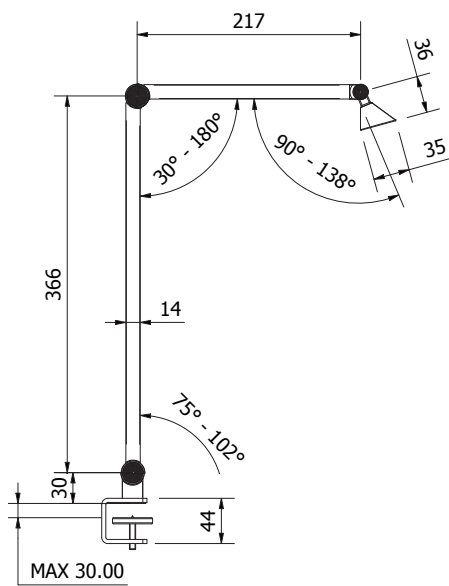

- **Construction** - Aluminium and Polymer
- **Colours** - White or Anthracite Black
- **Power cable** – 2 metres
- **Power supply** – 12W
- **Certified** - CE Certified
- **Energy usage** – Class E
- **Ingress-rated** - IP20
- **Double insulated** - Class II
- **Warranty** – 5 years\*

\*Subject to Terms and Conditions.



# Tern LED Task Light

One luminaire for all occasions.

Single monitors are becoming increasingly rare, and screens are growing larger and larger.



Office work is now almost exclusively carried out at desks with two or more monitors, making it increasingly strenuous for people's eyes. This trend drives the importance of high-quality, customisable illumination of the working environment to maintain performance and minimise eye strain.

With TERN, Adapt offers a unique, wide-angle lighting product with optimum flexibility in all directions. This complete flexibility ensures uniform illumination of the table surface, preventing shadows and providing optimum working conditions.

# Mounting Options



## SpaceArm Mount

The TERN light is attached directly to the SpaceArm mounting hub, ensuring ideal central positioning on double-monitor mounts with a space-saving shared table.



## C-Clamp

As standard, the TERN LED table lamp is available with a C-clamp attachment. This allows it to be securely attached in the required position at the rear or side edge of the tabletop.



## Tool Free

Tool-free installation, regardless of the mounting method.

Product Code	Description
LIHT-N3-T-CC-BLK	TERN LED table lamp with C-Clamp, colour black
LIHT-N3-T-SACC-BLK	TERN LED table lamp with SpaceArm adapter + C-Clamp, colour black
SPCA-514BK	Adapter for Tern Lighting, Assembly to SpaceArm Hub - Black



# Key Features



The flexible support post guides the Tern over the monitors onto the work surface and keyboard for optimum positioning of illumination.



The two lighting arms can be easily adjusted to match the angle of the monitors.



Furthermore, the two light strips can be independently swivelled to direct light to where it is required.



The two rotating light strips can also be used as a cantilevered table lamp when positioned in parallel.



Dimmable and colour temperature-adjustable illumination of the table surface in front of the monitors, without hot spots or glare.

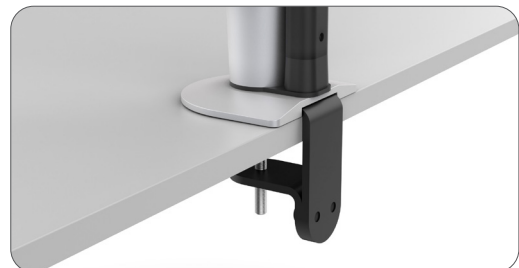

Shared attachment of the monitor arm and light for easier installation and more space on the table surface.



The lamp head features intuitive controls for the lighting functions, accessible via switches conveniently located within reach of the user.



A multifunction remote controller with lighting presets is also included.

# Light Adjustment

Multiple dimming and colour temperature adjustments.

Cold White  
6500 K



10%



20%



30%



40%



50%



60%



70%



80%



90%



100%  
1400 Lux



Daylight  
4000 K

Warm White  
2700 K



# Technical Specifications

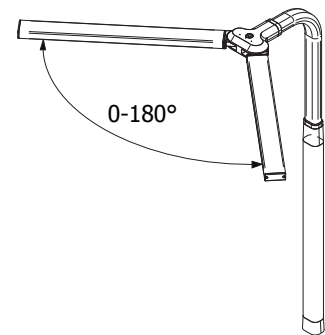
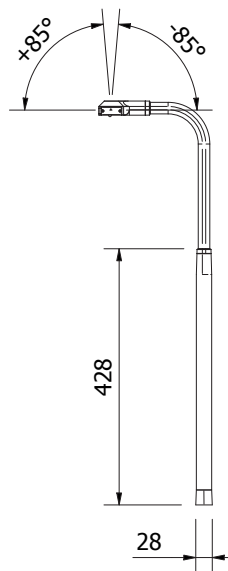
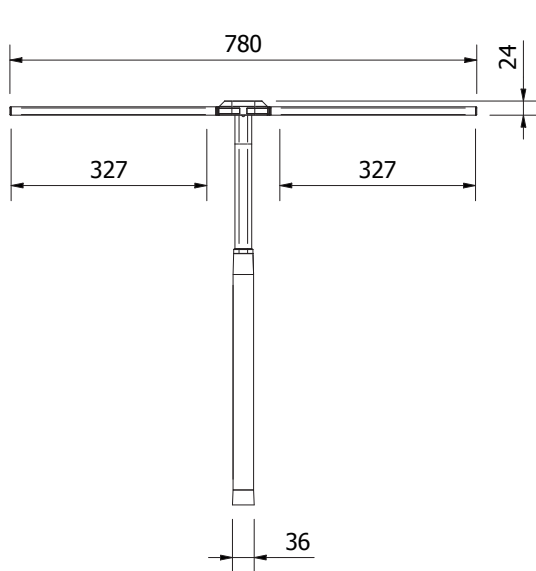
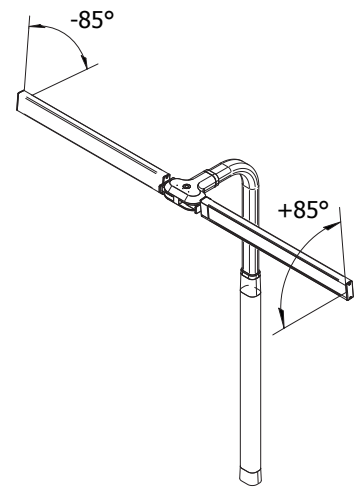
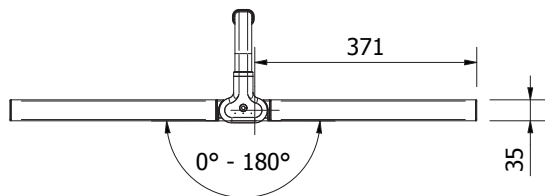

- **Materials** - Aluminium and plastics (ABS, PVC)
- **Colour** - Black
- **Colour temperature** - 2700K - 6500K, 10-step adjustable
- **Brightness** - 10-step adjustable (Max 1400 Lux at 6500 Kelvin)
- **Output** - 240V= 10A, 24W
- **Input** - 220-240V
- **CE conformity** - Yes
- **Energy Efficiency Class** - F
- **Protection class** - IP20
- **Warranty** - 2 Years



# Technical Specifications

## Standard C-Clamp

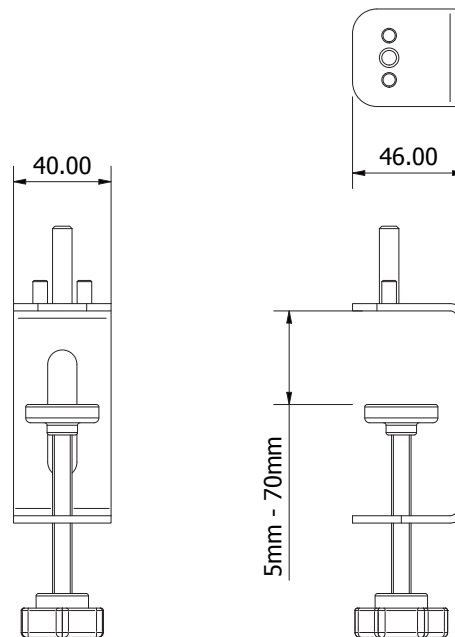

## SpaceArm Mount

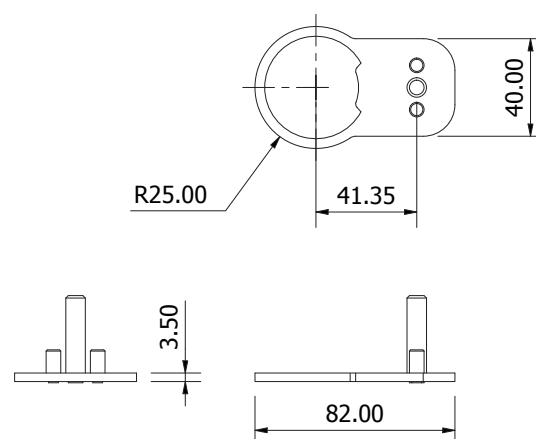

# Tubo Monitor Light Bar

## Why should you use a monitor light bar?

Whether your job is office-based or home-based, you use a laptop or standalone monitors, most of your working day is based around a computer screen. And when you are not working, you may be surfing the internet, keeping up with social media or gaming. Stop and think about how much time you spend staring at a screen.

Even if you have invested in the most up-to-date desk light in your work area, it is only going to provide an advantage for writing and reading tasks. The areas that are important when working at a computer screen often remain dark or shaded.



## Monitor Users Need Specialised Lighting.

Monitor light bars, such as Tubo, help alleviate eye strain from prolonged monitor use by reducing lighting contrast and eliminating glare on your screen, thereby creating a more comfortable environment for all screen-based activities.

As with all Adapt Lighting products, user comfort, improved ergonomics, health, and well-being are at the forefront of our solutions.

# Key Features and Benefits



Tubo's asymmetric design and custom optical glass help to reduce eye fatigue by eliminating high contrast areas, shadows and screen glare.



The Tubo light bar fits onto most curved or straight monitors as well as laptop screens, enabling you to target the light where you need it for maximum comfort and flexibility, whatever your set-up.



Tubo features simple controls on the light bar itself as well as an intuitive and convenient wireless remote control "puck". Multiple Tubo lights can be paired to one puck.



Take control of your lighting environment with simple-to-use dimmer and colour temperature adjustments and high Ra95 colour rendering index for natural colours.



The Tubo light bar provides exceptional performance without taking up any space on your desk or working area.



Tubo minimises disturbances with focused illumination compared to traditional LED lamps, making it ideal for working, surfing or gaming after dark.



Save energy by only lighting your working area rather than the entire room.



Low-voltage USB-powered LED lighting with a unique magnetic clip-on light bar makes Tubo safe, simple to install and easy to move around.

# Technical Specifications

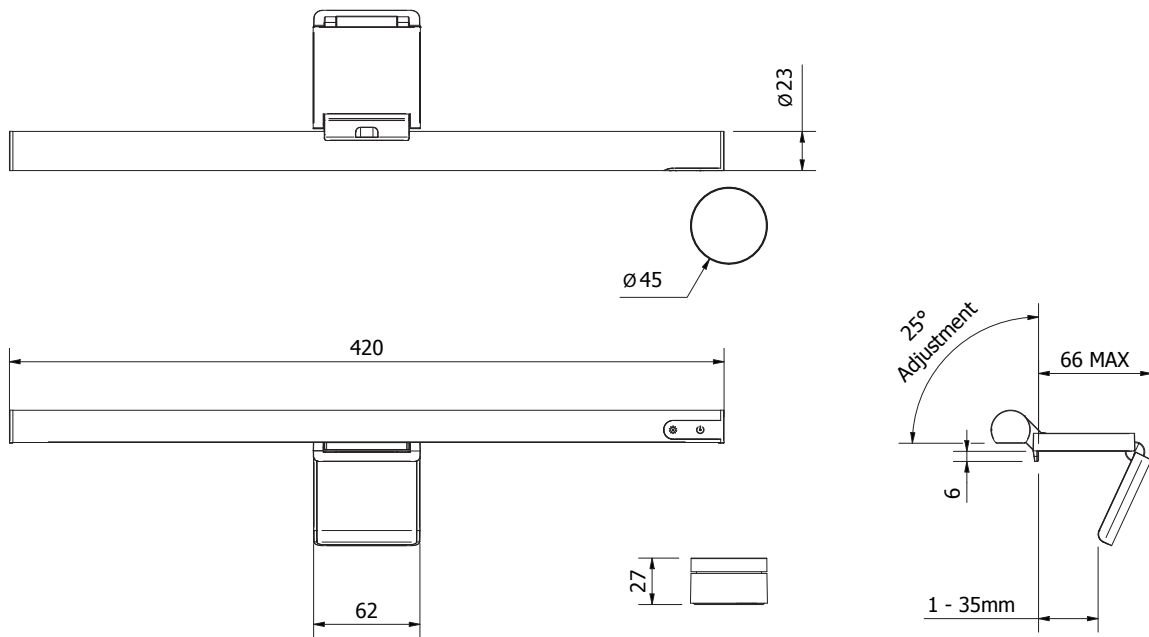
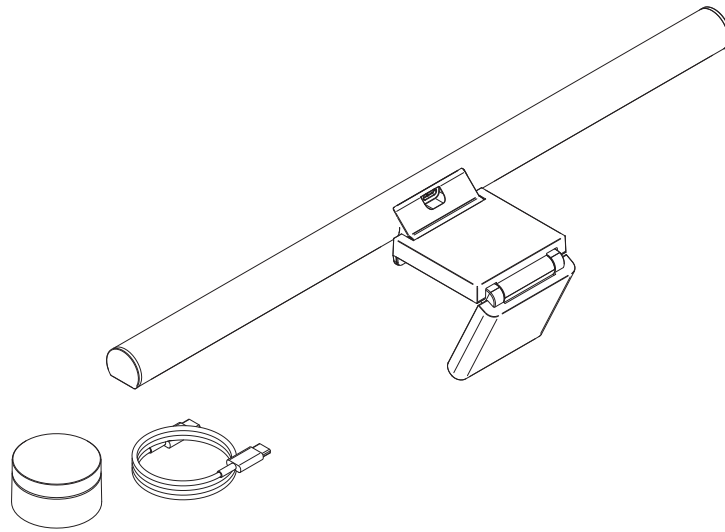

- **Output** - 270 Lumens
- **Beam angle** - 110°
- **Colour temperature** - 2700 to 6500 Kelvin
- **Connector** - USB-C
- **Power supply** - 5V x 1A
- **Energy class** - G
- **Max Brightness** - 550 Lux at 6500 Kelvin
- **Remote control puck** - 2.4-GHz wireless connection
- **Operating temperature** - -10 to +40°C
- **Construction** - Main components made of aluminium
- **Warranty** - 2 Years



# Key independent studies on individual task lighting

## 1 Controlled field study on adjustable task lighting (office setting)

- **Adjustable task lighting:** [Field study assesses the benefits in an office environment](#)
- **Authors:** Joines et al. (2015)
- **Type:** Randomised controlled field study (~100 participants)

### Key findings:

- **Adjustable LED task lighting has significantly improved:**
    - Visual comfort (reduced eye fatigue)
    - Musculoskeletal comfort
    - Posture (measured via ergonomic assessment tools)
  - No negative outcomes were reported
  - Demonstrates **direct ergonomic and perceptual benefits of individual control over lighting** ([PubMed](#))
- 

## 2 Exploratory field study on personal lighting conditions

- **Personal lighting conditions of office workers:** [An exploratory field study](#)
- **Authors:** van Duijnhoven et al. (2020)

### Key contributions:

- Investigates how **individual lighting setups vary between workers**
  - Shows that workers naturally adapt lighting (including task lights) to:
    - Task type
    - Personal preference
    - Time of day
  - Highlights the importance of **user-controlled lighting systems** rather than uniform ambient lighting ([Sage Journals](#))
- 

## 3 Survey-based study on lighting and worker outcomes

- **Subjective and objective survey of office lighting:** [effects on alertness, comfort, satisfaction, and safety](#)
- **Authors:** Rasouli Kahaki et al. (2022)

### Key findings:

- Lighting quality (including local/task lighting conditions) affects:
    - Alertness
    - Comfort
    - Job satisfaction
    - Safety perception
  - Both **objective measures (illuminance, colour temperature)** and subjective perceptions matter ([PMC](#))
- 

### URL References

- 1 <https://journals.sagepub.com/doi/10.3233/WOR-141879?>
- 2 <https://journals.sagepub.com/doi/10.1177/1477153520976940?>
- 3 <https://pmc.ncbi.nlm.nih.gov/articles/PMC9437655/?>



# Key independent studies on individual task lighting

## 4 Productivity effects of controllable task lighting (field study)

- **The influence of controllable task-lighting on productivity:** [A field study in a factory](#)
- **Type:** Longitudinal field experiment (16 months)

### Key findings:

- **Individual control over task lighting led to:**
    - ~4.5% productivity increase
  - **Mechanisms likely include:**
    - Improved visual performance
    - Psychological effects of control ([ScienceDirect](#))
- 

## 5 Broader review + pilot study on lighting responses in offices

- **Studying Response to Light in Offices:** [A Literature Review and Pilot Study](#)
- **Authors:** Collier et al. (2023)

### Key contributions:

- Synthesises decades of office lighting research
  - Highlights emerging methods for studying **individual exposure and response to lighting**
  - Supports shift toward **personalised lighting systems and adaptive environments** ([MDPI](#))
- 

### URL References

- 4 <https://www.sciencedirect.com/science/article/abs/pii/S0003687006000160?>
  - 5 <https://www.mdpi.com/2075-5309/13/2/471>
- 

# Key themes across independent research

Across these studies, there is strong convergence on several points:

## 1 Individual control is critical

- Personal/task lighting allows users to optimise for:
  - Task type
  - Visual comfort
  - Circadian preferences
- Consistently linked to improved satisfaction and comfort

## 2 Ergonomic benefits are measurable

- Reduced eye strain and musculoskeletal discomfort
- Improved posture when lighting reduces awkward viewing angles

## 3 Performance and productivity effects exist

- Measurable gains (though modest) in controlled studies
- Likely mediated by both physiological and psychological factors

## 4 One-size-fits-all lighting is suboptimal

- Workers exhibit large variability in preferred lighting levels
- Supports **task-ambient lighting strategies** (low ambient + personal task light)





Create workspaces that work.

Contact Adapt Deutschland GmbH for more information,  
pricing and samples.

+49 (0) 2151 985 190

[info@adapt-deutschland.eu](mailto:info@adapt-deutschland.eu)

[www.adapt-deutschland.eu](http://www.adapt-deutschland.eu)